

# Quarter Turn Electric Actuator

## Product Catalogue For Control Valves

[www.mastork.mx](http://www.mastork.mx)



**50/60Hz, 1 Phase / 3 Phase, AC/DC, On/Off, Modulating type**



Specification	EOM2	EOM3	EOM3A	EOM4	EOM5	EOM6	EOM7	EOM7A	EOM8	EOM8A	EOM9
Max Torque(N.m)	100	200	300	400	600	800	1000	1300	1700	2000	2300
Max Torque(lbf.in)	885	1770	2655	3540	5310	7080	8850	11505	15045	17700	20355
Operation Time(Sec) @ 110/220VAC	16	17	18	19	20	21	22	23	24	25	34
Operation Time(Sec) @ 24V	19	39	39	29	39	47	47	-	-	-	-
Power ( Watts)	0 4			0 9			0 2 1		0 0 2		
Standard Voltage	1 Phase: 50 Hz AC 220 / 230 / 240 , 60 Hz AC 110 / 120 / 220 / 230 / 240, ±10 %										
Optional Voltage	3 Phase: 50 Hz AC 220 / 240 / 380 / 400 / 460, 60 Hz AC 220 / 230 / 240 / 380 / 440 / 460 / 480, ±10 %										
	AC / DC 24V										
Control Signal	On/Off digital signal; Modulating, 4~20mA or 0-10V or 2-10V										
Feedback Signal	On/Off - Dry contact position feedback; (rated 5A @250V AC) Modulating - 4-20mA or 0-10V or 2-10V position analog feedback;										
Duty Cycle	On/Off: S2~15min ( ≤ 60 starts per hour), Modulating: S4~50% ( 600 trigger per hour)										
Standard Features											
Enclosure	IP67										
Motor Stall Protection	F grade motor with built in thermal protection ( Open 135° ± 5%, Close 90° ± 5%) (Available to AC current motor)										
Space Heater	Anti condensation alloy heating resistance										
Manual Override	Standard handwheel, Non-Clutch mechanism for automatic manual switch										
Mechanical Stopper	1 each, external adjustable for open and close travels										
Limit Switches	2 x Open / Close, 5A @250VAC Switches, 2 x auxiliary limit switches										
Gear type	Planetary eccentric gear										
Indicator	3D position indicator										
External Coating	Epoxy Powder Coating										
Travel Angle	90° (± 5°)										
Ambient Temperature	-25 °C ... +70 °C										
Housing	Alluminium alloy										

## 50/60Hz, 1 Phase / 3 Phase, AC/DC, On/Off, Modulating type

Optional Features	
Torque Switch	1 x Open / Close, 5A @250VAC
Enclosure	IP68 ( 15m under water for max. 72 hours )
Motor	H grade motor (75% duty cycle)
Positional Feedback	1KΩ Potentiometer unit / 4-20mA feedback
Explosion Proof	ATEX / Nepsi / IECEx / CSA / Ex d IIC T4~6 Gb Ex tb IIICT135°C or Ex d IIC T4~6 Gb Ex tb IIICT135°C
Local Control Unit	Knob type: Open / Stop / Close / Local / Remote
	Infrared remote controller for non intrusive menu setting
Local Display Unit	Lamp display type: Open / Stop / Close
	LCD display type: Open / Close percentage
Communication Bus	Modbus / Profibus/ Hart ( Available for LCD display unit model)
Fault Feedback	Fault signal: Power lost / motor overheating / lack of phase / over torque / lost of signal
Fail-Safe	Lithium battery fail safe: (Only with model not exceeding 1000N.m.)
Coating	NEMA4 / 4X anti corrosion epoxy coating
Phase Correction	Automatic phase sequence correction (Only for 3 phase)
	

ISO 5211 Mounting	EOM2	EOM3	EOM3A	EOM4	EOM5	EOM6	EOM7	EOM7A	EOM8	EOM8A	EOM9
Valve Coupling	F05 / F07 / F10 / F12			F10 / F12 / F14			F12 / F14 / F16				
Multi-drilled	F07 + F10			F10 / F12			N / A				
Square drive size	14mm / 17mm / 22mm			22mm / 27mm / 30mm			27mm/30mm/36mm/37mm				
Max. Diameter	22 mm			35 mm			45 mm				
Max. Two Flat	22 mm			30 mm			37 mm				
Max. Valve Stem length	35 mm			55 mm			65 mm				

Note: Alternative size can be customized made, please consult with service staff.

50/60Hz, 1 Phase / 3 Phase, AC/DC, On/Off, Modulating type

Dimension (mm)	EOM2	EOM3	EOM3A	EOM4	EOM5	EOM6	EOM7	EOM7A	EOM8	EOM8A	EOM9
A	268				327				380		
B	77				103				127		
C	123				187				242		
D	216				266				293		
E	121				150				161		
F	240				297				333		
G	14 / 17 / 22				22 / 27 / 30				27 / 30 / 36 / 37		
H	35				55				65		
ΦI	50 / 70 / 102 / 125				102 / 125 / 140				125 / 140 / 165		
J	4-M8				4-M10 / 4-M12		4-M12		4-M12		4-M16
Weight(kg)	11				22				36		

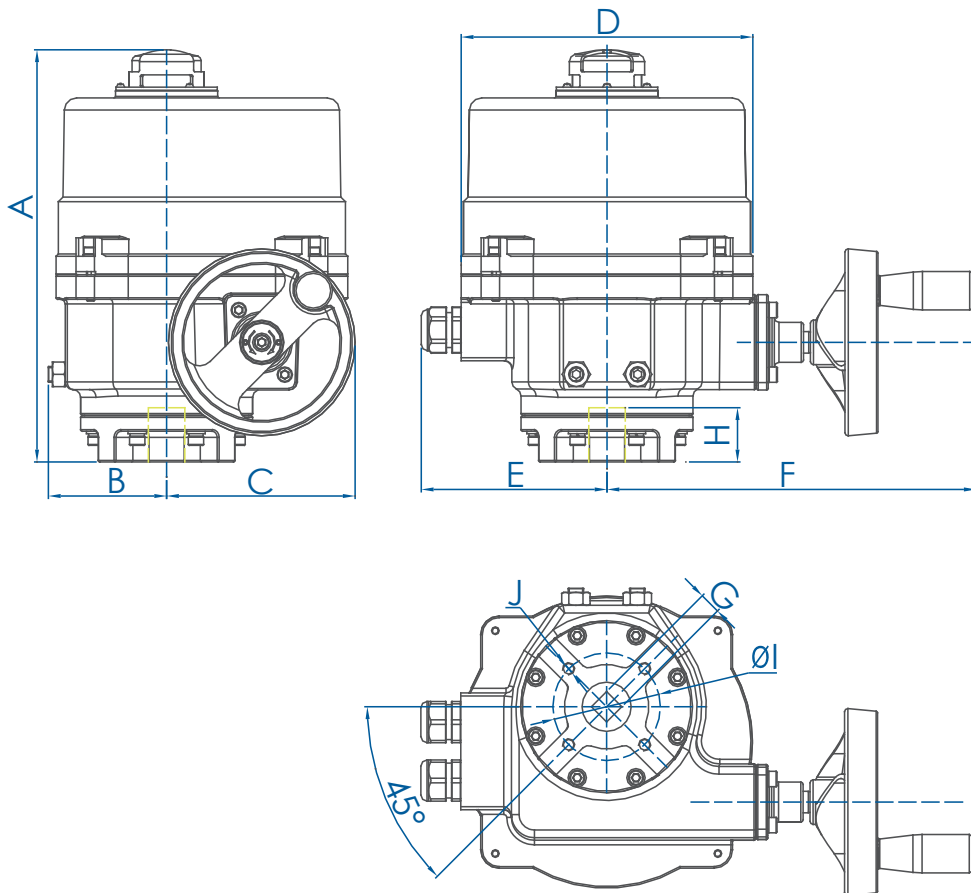

50/60Hz, 1 Phase / 3 Phase, AC/DC, On/Off, Modulating type

**Basic Wiring Diagram Only for reference; please refer to diagram inside actuator)**

**AC110V / 120V / 220V / 230V On/Off type wiring diagram**

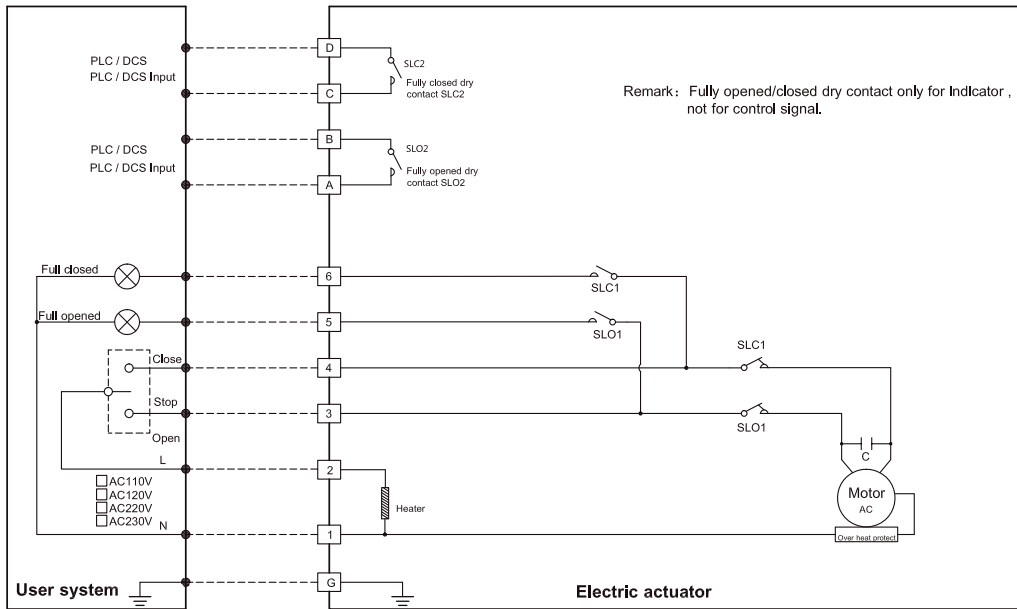

Be sure to connect the protective earth terminal G.

**AC110V / 120V / 220V / 230V Modulating type wiring diagram**

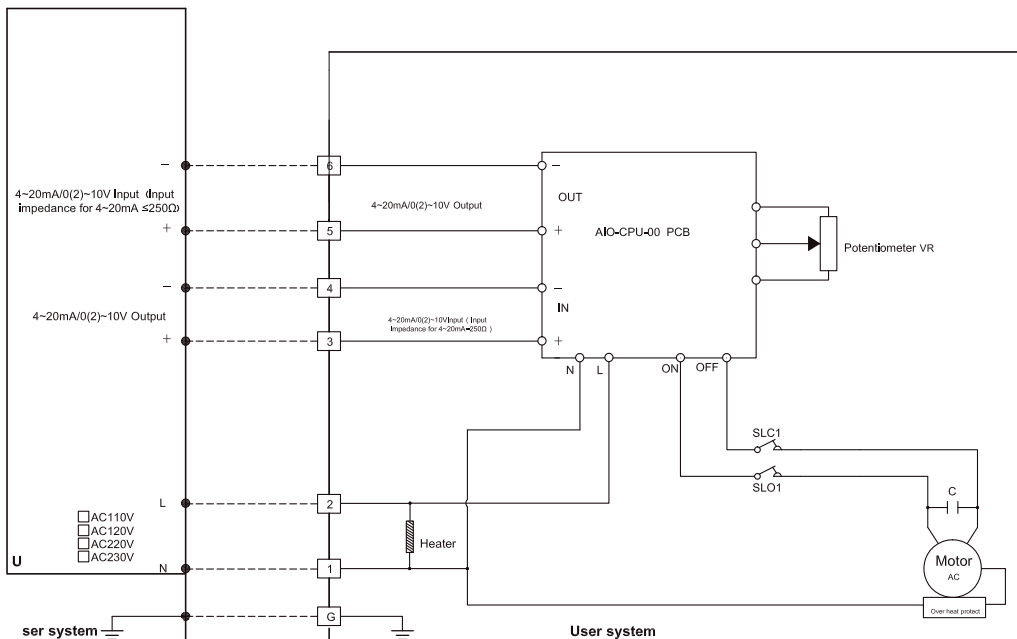

Be sure to connect the protective earth terminal G.

# 50/60Hz, 1 Phase / 3 Phase, AC/DC, On/Off, Modulating type

**Basic Wiring Diagram (Only for reference; please refer to diagram inside actuator)**

## AC/DC24V On/Off type wiring diagram

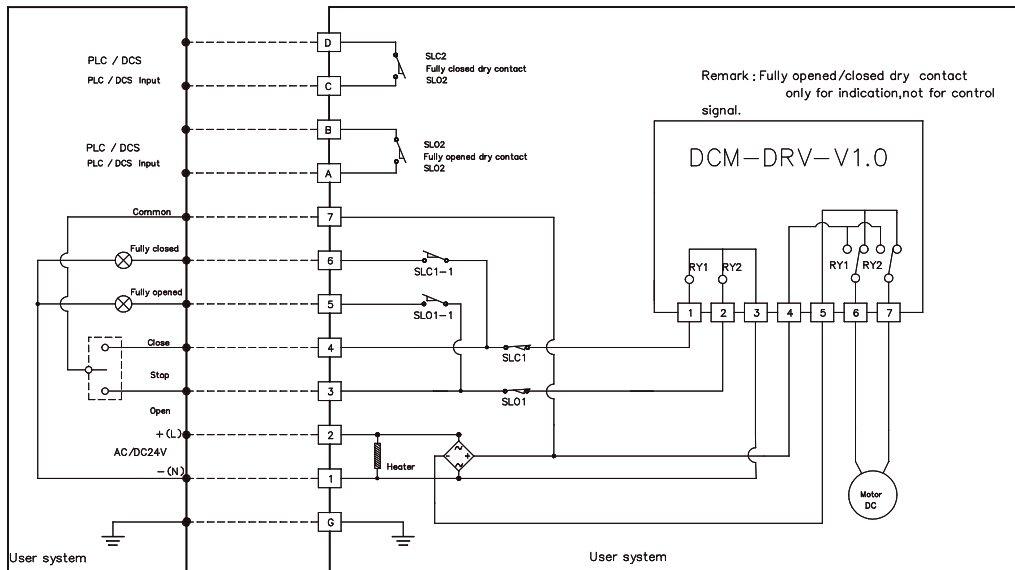

⚠ Be sure to connect the protective earth terminal G.

## AC24V Modulating type wiring diagram

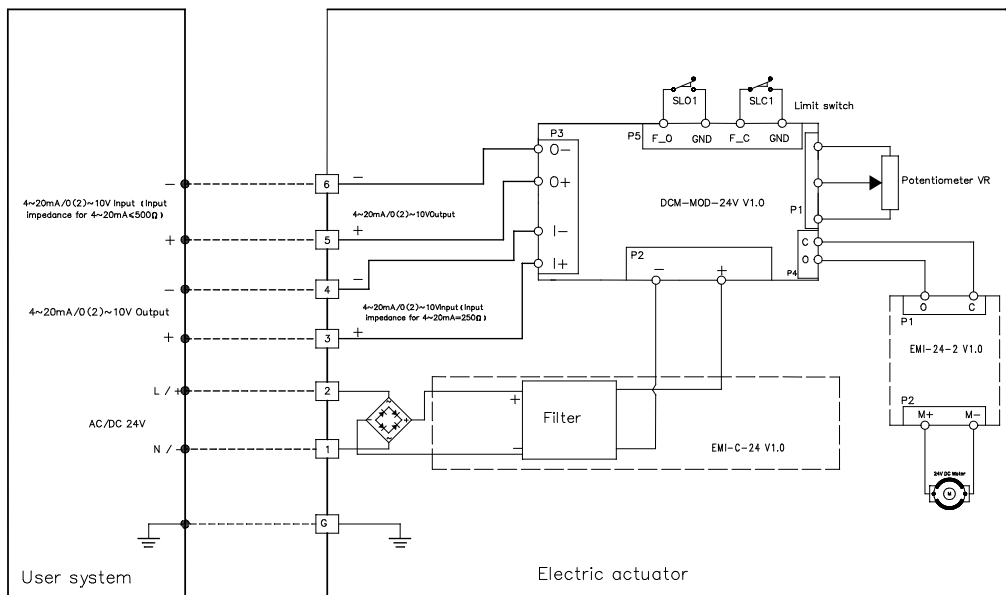

⚠ Be sure to connect the protective earth terminal G.